

APPROVAL SHEET

**WF06P, WF08P, WF12P, WF10P, WF20P,
WF25P**

±1%, ±5% 0Ω, 1Ω~1MΩ

Thick film High Power Chip Resistors

Size 0603, 0805, 1206, 1210, 2010, 2512

(Automotive Grade)

*Contents in this sheet are subject to change without prior notice.

FEATURE

1. Automotive grade AEC Q-200 compliant
2. 100% CCD inspection
3. RoHS compliant and Lead free products
4. High power rating

APPLICATION

1. High accuracy dc-power supply
2. Digital multi-meter
3. Telecommunication
4. Computer
5. Automotive industry
6. Medical and military equipment

DESCRIPTION

The resistors are constructed in a high grade ceramic body (aluminum oxide). Internal metal electrodes are added at each end and connected by a resistive paste that is applied to the top surface of the substrate. The composition of the paste is adjusted to give the approximate resistance required and the value is trimmed to nominated value within tolerance which controlled by laser trimming of this resistive layer.

The resistive layer is covered with a protective coat. Finally, the two external end terminations are added. For ease of soldering the outer layer of these end terminations is a Tin (lead free) alloy.

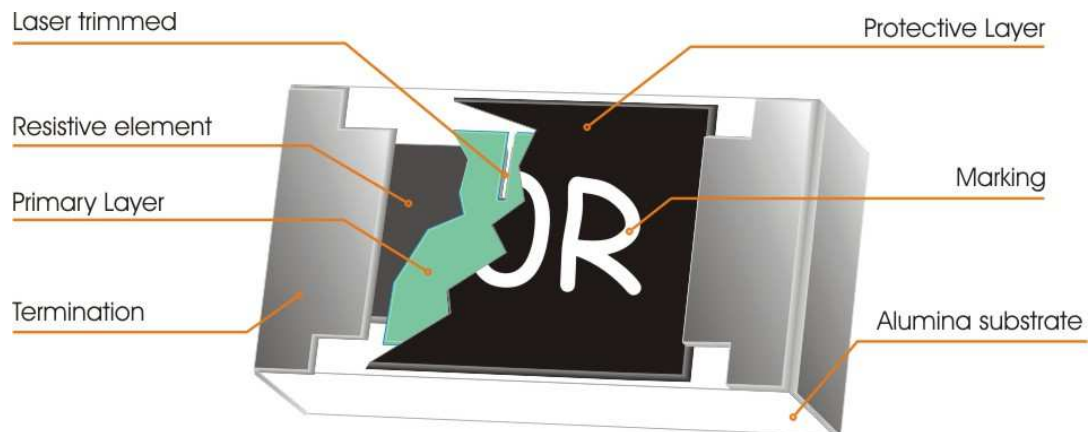

Fig 1. Construction of Chip-R

QUICK REFERENCE DATA

Item	General Specification					
Series No.	WF06P	WF08P	WF12P	WF10P	WF20P	WF25P
Size code	0603 (1608)	0805 (2012)	1206 (3216)	1210 (3225)	2010 (5025)	2512 (6432)
Resistance Tolerance	±1%, ±5%					
Resistance Range	0Ω, 1Ω~ 1MΩ (E96+E24 series)					
TCR (ppm/°C) 20°C ~ +155°C 10.2Ω ~ 1MΩ 1Ω ~ 10Ω	≤ ± 100	≤ ± 100	≤ ± 100	≤ ± 100 ≤ ± 200	≤ ± 100	
TCR (ppm/°C) 20°C ~ - 55°C 10.2Ω ~ 1MΩ 1Ω ~ 10Ω	≤ ± 100	≤ ± 100		≤ ± 100 ≤ ± 200		
Max. dissipation at T _{amb} =70°C	1/8 W	1/4 W	1/2W	1/2W	1W	2W
Max. Operation Voltage	50V	150V	200V	200V	200V	300V
Max. Overload Voltage	100V	300V	400V	400V	400V	500V
Operation temperature	-55 ~ +155°C					

Note :

- This is the maximum voltage that may be continuously supplied to the resistor element, see "IEC publication 60115-8"
- Max. Operation Voltage : So called RCWV (Rated Continuous Working Voltage) is determined by

$$RCWV = \sqrt{\text{Rated Power} \times \text{Resistance Value}}$$
or Max. RCWV listed above, whichever is lower.

DIMENSIONS (unit : mm)

Part No	WF06P	WF08P	WF12P	WF10P	WF20P	WF25P
L	1.60 ± 0.10	2.00 ± 0.10	3.10 ± 0.15	3.10 ± 0.10	5.00 ± 0.20	6.30 ± 0.20
W	0.80 ± 0.10	1.25 ± 0.10	1.60 ± 0.15	2.60 ± 0.10	2.50 ± 0.20	3.10 ± 0.20
T	0.45 ± 0.15	0.50 ± 0.15	0.55 ± 0.10	0.55 ± 0.10	0.60 ± 0.10	0.60 ± 0.15
Tt	0.30 ± 0.10	0.40 ± 0.20	0.50 ± 0.25	0.50 ± 0.20	0.60 ± 0.25	0.60 ± 0.25
Tb	0.30 ± 0.15	0.40 ± 0.20	0.50 ± 0.25	0.50 ± 0.20	0.60 ± 0.25	1.80 ± 0.25

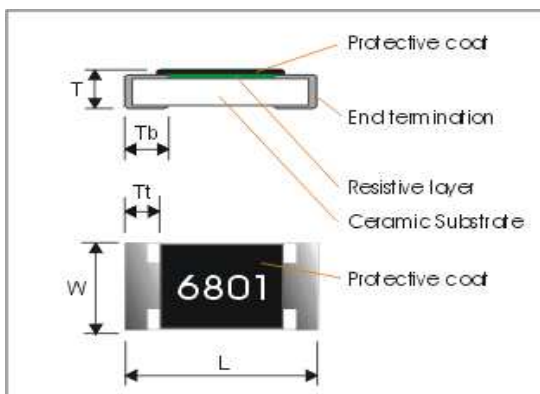

MARKING

Size \ Nr. Of digit of code \ tolerance	$\pm 5\%$	$\pm 1\%$
2512 (6432)	3-digits marking	4-digits marking
2010 (5025)	3-digits marking	4-digits marking
1210 (3225)	3-digits marking	4-digits marking
1206 (3216)	3-digits marking	4-digits marking
0805 (2012)	3-digits marking	4-digits marking
0603 (1608)	3-digits marking	3-digits marking

3-digits marking ($\pm 5\%$: 2512, 2010, 1210, 1206, 0805, 0603)

Each resistor is marked with a three digits code on the protective coating to designate the nominal resistance value.

3-digits marking ($\pm 1\%$: 0603)

Nominal resistance		Description													
1.E-24 series		As 0603 WR06X $\pm 5\%$.													
2.E-96 series		The 1st two digit codes are referring to the CODE on the table, the 3rd code is the index of resistance value : $Y=10^{-2}$, $X=10^{-1}$, $A=10^0$, $B=10^1$, $C=10^2$, $D=10^3$, $E=10^4$, $F=10^5$ EX: 17.8 Ω =25X, 178 Ω =25A, 1K78 =25B 17K8=25C, 178K=25D, 1M78=25E													
3. Remark		There is no marking for the items are not under E-24 and E-96 series													
CODE	R_value	CODE	R_value	CODE	R_value	CODE	R_value	CODE	R_value	CODE	R_value	CODE	R_value	CODE	R_value
01	100	13	133	25	178	37	237	49	316	61	422	73	562	85	750
02	102	14	137	26	182	38	243	50	324	62	432	74	576	86	768
03	105	15	140	27	187	39	249	51	332	63	442	75	590	87	787
04	107	16	143	28	191	40	255	52	340	64	453	76	604	88	806
05	110	17	147	29	196	41	261	53	348	65	464	77	619	89	825
06	113	18	150	30	200	42	267	54	357	66	475	78	634	90	845
07	115	19	154	31	205	43	274	55	365	67	487	79	649	91	866
08	118	20	158	32	210	44	280	56	374	68	499	80	665	92	887
09	121	21	162	33	215	45	287	57	383	69	511	81	681	93	909
10	124	22	165	34	221	46	294	58	392	70	523	82	698	94	931
11	127	23	169	35	226	47	301	59	402	71	536	83	715	95	953
12	130	24	174	36	232	48	309	60	412	72	549	84	732	96	976

4-digits marking ($\pm 1\%$: 2512/ 2010/ 1210/ 1206/ 0805)

Each resistor is marked with a four digits code on the protective coating to designate the nominal resistance value.

Example

RESISTANCE	10 Ω	12 Ω	100 Ω	6800 Ω	47000 Ω
3-digits marking (1206 & 0805 & 0603 $\pm 5\%$)	100	120	101	682	473
4-digits marking	10R0	12R0	1000	6801	4702

FUNCTIONAL DESCRIPTION

Product characterization

Standard values of nominal resistance are taken from the E96&E24 series for resistors with a tolerance of $\pm 1\%$, $\pm 5\%$. The values of the E96/E24 series are in accordance with "IEC publication 60063".

Derating

The power that the resistor can dissipate depends on the operating temperature; see Fig.2

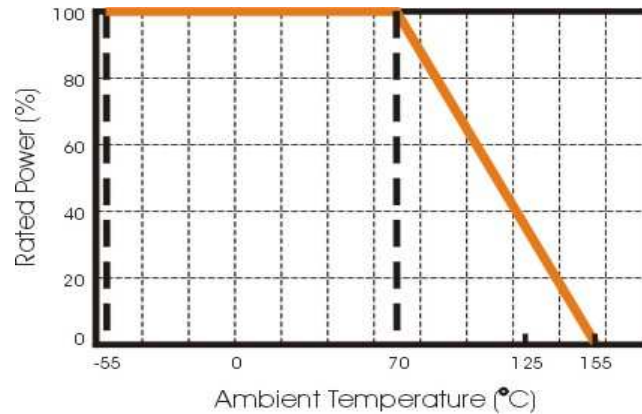

Fig.2 Maximum dissipation in percentage of rated power
As a function of the ambient temperature

MOUNTING

Due to their rectangular shapes and small tolerances, Surface Mountable Resistors are suitable for handling by automatic placement systems.

Chip placement can be on ceramic substrates and printed-circuit boards (PCBs).

Electrical connection to the circuit is by individual soldering condition.

The end terminations guarantee a reliable contact.

SOLDERING CONDITION

The robust construction of chip resistors allows them to be completely immersed in a solder bath of 260°C for 10 seconds. Therefore, it is possible to mount Surface Mount Resistors on one side of a PCB and other discrete components on the reverse (mixed PCBs).

Surface Mount Resistors are tested for solderability at 235°C during 2 seconds. The test condition for no leaching is 260°C for 30 seconds. Typical examples of soldering processes that provide reliable joints without any damage are given in Fig 3.

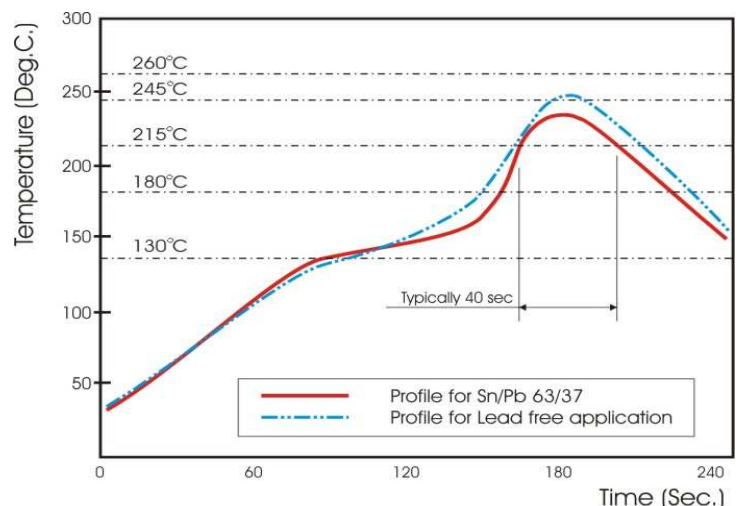

Fig 3. Infrared soldering profile for Chip Resistors

CATALOGUE NUMBERS

The resistors have a catalogue number starting with .

WF08	P	1002	F	T	L	J
Size code WF06: 0603 WF08: 0805 WF12: 1206 WF10: 1210 WF20: 2010 WF25: 2512	Type code P :Power 0603 size = 1/8W 0805 size = 1/4W 1206 size = 1/2W 1210 size = 1/2W 2010 size = 1W 2512 size = 2W	Resistance code 5%, E24: 2 significant digits followed by No. of zeros e.g.: 3ohm =3R0 10ohm =100 56Kohm =563 1%, E24+E96: 3 significant digits followed by No. of zeros 100Ω =1000 37.4KΩ =3742	Tolerance J : ±5% F : ±1% P : Jumper	Packaging code T: 7" Reeled taping .	Termination code L = Sn base (lead free)	Special code J = Automotive grade and Anti-Sulfuration 10ppm x 240hrs

- Reeled tape packaging : 8mm width paper taping 5000pcs per 7" reel for 0603-1210 sizes.
- Reeled tape packaging : 12mm width plastic taping 4000pcs per 7" reel for 2010, 2512 sizes.

TEST CONDITIONS FOR JUMPER (0 Ω)

Item	WF25P	WF20P	WF12P	WF10P	WF08P	WF06P
Power Rating At 70°C	2W	1W	1/2W	1/2W	1/4W	1/8W
Resistance	Max. 20mΩ					
Rated Current	10A	7A	5A	5A	3.5A	2.5A
Peak Current	25A	17.5A	12.5A	12.5A	8.8A	6.2A
Operating Temperature	-55 ~ +155°C					

TEST AND REQUIREMENTS

Essentially all tests are carried out according to the schedule of IEC publication 115-8, category **LCT/UCT/56**(rated temperature range : **Lower Category Temperature, Upper Category Temperature**; damp heat, long term, 56 days). The testing also meets the requirements specified by EIA, EIAJ and JIS.

The tests are carried out in accordance with IEC publication 68, "Recommended basic climatic and mechanical robustness testing procedure for electronic components" and under standard atmospheric conditions according to IEC 60068-1, subclause 5.3. Unless otherwise specified, the following value supplied :

Temperature: 15°C to 35°C.

Relative humidity: 45% to 75%.

Air pressure: 86kPa to 106 kPa (860 mbar to 1060 mbar).

All soldering tests are performed with midly activated flux.

TEST	PROCEDURE / TEST METHOD	REQUIREMENT
		Resistor
Electrical Characteristics JISC5201-1: 1998 Clause 4.8	- DC resistance values measurement - Temperature Coefficient of Resistance (T.C.R) Natural resistance change per change in degree centigrade. $\frac{R_2 - R_1}{R_1(t_2 - t_1)} \times 10^6 \text{ (ppm/}^\circ\text{C)} \quad t_1 : 20^\circ\text{C}+5^\circ\text{C}-1^\circ\text{C}$ R ₁ : Resistance at reference temperature R ₂ : Resistance at test temperature	Within the specified tolerance Refer to "QUICK REFERENCE DATA"
Resistance to soldering heat(R.S.H) MIL-STD-202 method 210	Un-mounted chips completely immersed for 10±1second in a SAC solder bath at 270°C ±5°C	ΔR/R max. ±(1.0%+0.05Ω) no visible damage
Solderability J-STD-002	a) Bake the sample for 155°C dwell time 4hrs/ solder dipping 235°C/ 5sec. b) Steam the sample dwell time 8 hour/ solder dipping 215°C/ 5sec. c) Steam the sample dwell time 8 hour/ solder dipping 260°C/ 7sec.	95% coverage min., good tinning and no visible damage
Temperature cycling JESD22 Method JA-104	1000 cycles, -55°C ~ +155°C, dwell time 30min maximum.	ΔR/R max. ±(1.0%+0.05Ω) No visible damage
Moisture Resistance MIL-STD-202 method 106	65±2°C, 80~100% RH, 10 cycles, 24 hours/ cycle	ΔR/R max. ±(1.0%+0.05Ω) No visible damage
Bias Humidity MIL-STD-202 method 103	1000+48/-0 hours; 85°C, 85% RH, 10% of operation power	ΔR/R max. ±(2.0%+0.10Ω) No visible damage
Operational Life MIL-STD-202 method 108	1000+48/-0 hours; 35% of operation power, 125±2°C	ΔR/R max. ±(2.0%+0.1Ω) No visible damage
High Temperature Exposure MIL-STD-202 Method 108	1000+48/-0 hours; without load in a temperature chamber controlled 155±3°C	ΔR/R max. ±(2.0%+0.10Ω) No visible damage
Board Flex AEC-Q200-005	Resistors mounted on a 90mm glass epoxy resin PCB(FR4),bending once 2mm for 60sec.	ΔR/R max. ±(1.0%+0.05Ω) No visible damage

Terminal strength AEC-Q200-006	Pressurizing force: 1Kg, Test time: 60±1sec.	No remarkable damage or removal of the terminations
Thermal shock MIL-STD-202 method 107	Test -55 to 155°C/ dwell time 15min/ Max transfer time 20sec 300cycles	ΔR/R max. ±(1.0%+0.05Ω) No visible damage
ESD AEC-Q200-002	Test contact 1.0KV (0.5KV for 0402 only)	ΔR/R max. ±(1.0%+0.05Ω) No visible damage
Mechanical Shock MIL-STD-202 method 213	Test ½ Sine Pulse, Peak value: 100g, normal duration: 6ms, Velocity change:12.3ft/sec. Three shocks in each direction, total 18 shocks.	Within product specification tolerance and no visible damage.
Vibration MIL-STD-202 method 204	Test 5g's for 20 min., 12 cycles each of 3 orientations.	△R/R max. ±(1%+0.05Ω) and no visible damage
Resistance to Solvents : MIL-STD-202 Method 215	Solvent is Isopropyl alcohol, immersion 3mins at 25°C and brush 10 strokes with a toothbrush with a handle made of a non-reactive material (wet bristle), immersion and brush 3 times and then air blow dry.	No superficial defect on marking, encapsulation, coating, appearance. Electrical characteristics within products specification and tolerance. Inspect at 3X max. for marking, inspect at 10X for part damage.
External Visual MIL-STD-883 method 2009	Electrical test not required. Inspect device construction, marking and workmanship	No visual damage and refer WTC marking code.
Physical Dimension JESD22 method JB-100	Verify physical dimensions(L, W, T, Tb, Tt)	Within the specified tolerance for WTC.

PACKAGING

Paper Tape specifications (unit :mm)

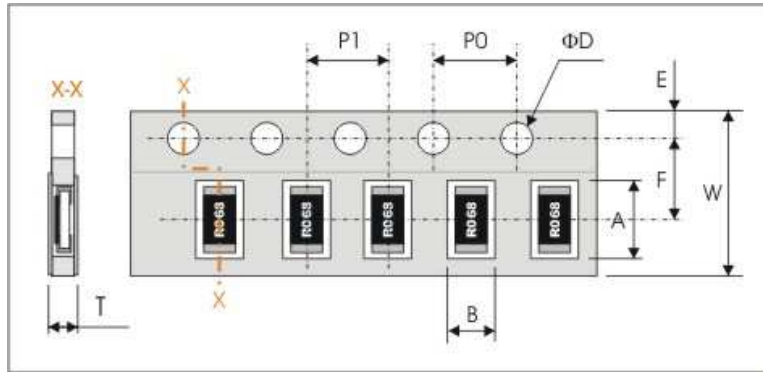

Series No.	A	B	W	F	E
WF25P	6.90±0.20	3.20±0.20	12.00±0.30	5.50±0.10	1.75±0.10
WF20P	5.50±0.20	2.80±0.20	12.00±0.30	5.50±0.10	1.75±0.10
WF10P	3.60±0.20	3.00±0.20	8.00±0.30	3.50±0.20	1.75±0.10
WF12P	3.60±0.20	2.00±0.20			
WF08P	2.40±0.20	1.65±0.20			
WF06P	1.90±0.20	1.10±0.20			

Series No.	P1	P0	ΦD	T
WF25P	4.00±0.10	4.00±0.10	Φ1.50 ^{+0.1} _{-0.0}	Max. 1.2
WF20P				Max. 1.2
WF10P				Max. 1.0
WF12P				Max. 1.0
WF08P				Max. 1.0
WF06P				0.65±0.05

Reel dimensions

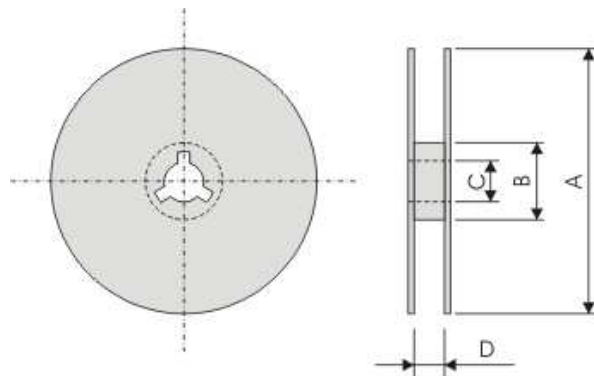

Symbol	A	B	C	D
12 mm tape	Φ178.0±2.0	Φ60.0±1.0	13.0±0.2	12.4±1.0
8 mm tape	Φ178.0±2.0	Φ60.0±1.0	13.0±0.2	9.0±0.5